

# GRW165P



Generator engineered and designed to work in a wide variety of applications where temporary power supply is needed. Versatility, high efficiency, high structural resistance, high degree of protection and low noise emissions together with easy-to-use and easy access for maintenance make these generator sets the ideal solution for Rental companies.

## Power Rating

Frequency	Hz	50
Voltage	V	400
Phases	Nº	3
Power factor	cos $\phi$	0.8
Standby power LTP	kVA	165.00
Standby power LTP	kW	132.00
MAX current	A	238
Prime power PRP	kVA	150.00
Prime power PRP	kW	120.00
NOMINAL current	A	217



## Ratings definition (According to standard ISO8528 1:2005)

### PRP - Prime Power:

It is defined as being the maximum power which a generating set is capable of delivering continuously whilst supplying a variable electrical load when operated for an unlimited number of hours per year under the agreed operating conditions with the maintenance intervals and procedures being carried out as prescribed by the manufacturer. The permissible average power output over 24 h of operation shall not exceed 70 % of the prime power.

### LTP - Limited-Time running Power:

It is defined as the maximum power available, under the agreed operating conditions, for which the generating set is capable of delivering for up to 500 h of operation per year (whose no more than 300 for continuative use) with the maintenance intervals and procedures being carried out as prescribed by the manufacturers. No overload capability is available.

**Power supply 50Hz 230V Three Phase (with supplement VSS)**

Frequency	Hz	50
Voltage	V	230
Phases	№	3
Power factor	cos $\phi$	0.8
Standby power LTP	kVA	165.00
Standby power LTP	kW	132.00
MAX current	A	414
Prime power PRP	kVA	150.00
Prime power PRP	kW	120.00
NOMINAL current	A	377

**Power supply 60Hz 480V Three Phase (with supplement DFS)**

Frequency	Hz	60
Voltage	V	480
Phase	№	3
Power factor	cos $\phi$	0.8
Standby power LTP	kVA	187.77
Standby power LTP	kW	150.22
MAX current	A	226
Prime power PRP	kVA	169.81
Prime power PRP	kW	135.85
NOMINAL current	A	204

**Power supply 60Hz 208V Three Phase (with supplement VSS)**

Frequency	Hz	60
Voltage	V	208
Phase	№	3
Power factor	cos $\phi$	0.8
Standby power LTP	kVA	179.00
Standby power LTP	kW	143.20
MAX current	A	497
Prime power PRP	kVA	163.00
Prime power PRP	kW	130.40
NOMINAL current	A	452



## Engine specifications

Engine manufacturer	Perkins	
Model	1106D-E70TAG2	
Engine cooling system	Water	
Nr. of cylinder and disposition	6 in line	
Displacement	cm <sup>3</sup>	7010
Aspiration	Turbocharged	
Speed governor	Electronic	
Oil capacity	l	17.5
Lube oil consumption @ PRP (max)	%	0.1
Coolant capacity	l	21
Electric circuit	V	12
VERSION SWITCHABLE [50/60Hz]	YES	
ENGINE DATA	Hz	50
[50Hz] Operating Speed-Nominal	rpm	1500
[50Hz] Exhaust emission level	Stage IIIA	
[50Hz] Specific fuel consumption @ 75% PRP	g/kWh	229.6
[50Hz] Specific fuel consumption @ 100% PRP	g/kWh	216.5
ENGINE DATA	Hz	60
[60Hz] Operating Speed-Nominal	rpm	1800
[60Hz] Exhaust emission optimized for EPA tier (EPA)	Tier 3	
[60Hz] Specific fuel consumption @ 75% PRP	g/kWh	231.4
[60Hz] Specific fuel consumption @ 100% PRP	g/kWh	214.6



## Engine Equipment

### Standards

The above ratings represent the engine performance capabilities to conditions specified in ISO 8528/1, ISO 3046/1:1986, BS 5514/1

### Fuel system

Rotary type pump

### Lube oil system

Wet steel sump with filler and dipstick

### Filter

- Fuel filter
- Air filter
- Oil filter

### Cooling system

- Mounted radiator
- Thermostatically-controlled system with belt driven coolant pump and pusher fan

## Alternator Specifications

Alternator	LEROY SOMER
Model	LSA 44.3 L10
Type	Brushless
Class	H
IP protection	23
Winding insulation	Protection System 2
Poles	4
Winding leads	12
Voltage regulation system	Electronic
Standard AVR	R 438
Voltage tolerance	% 1



### SPECIALY ADAPTED TO APPLICATIONS

The LSA 44.3 alternator is designed to be suitable for typical generator applications, such as: backup, marine applications, rental, telecommunications, etc.

### TOP OF THE RANGE ELECTRICAL PERFORMANCE

- Class H insulation.
- Standard 12 wire re-connectable winding, 2/3 pitch, type no. 6.
- Voltage range:
  - 50 Hz: 220 V - 240 V and 380 V - 415 V
  - 60 Hz: 208 V - 240 V and 380 V - 480 V
- High efficiency and motor starting capacity.
- R 791 interference suppression conforming to standard EN 55011 group 1 class B standard for European zone (CE marking).

### EXCITATION AND REGULATION SYSTEM

- Excitation system: AREP
- Voltage A.V.R.: R 438

### REINFORCED MECHANICAL STRUCTURE

- Compact rigid assembly to better withstand generator vibrations.
- Steel frame and terminal box.
- Aluminium flanges and shields.
- Single-bearing designed to be suitable for heat engines.
- Half-key balancing bearing.
- Permanently greased bearing (20 000h).

### PROTECTION SYSTEM SUITED TO THE ENVIRONMENT

- The LSA 44.3 is IP 23.
- Winding Protection Standard: for clean environments with relative humidity  $\leq 95\%$ , including indoor marine environments.
- Winding Protection System 2: reinforced insulation for tropical environment (abrasive atmosphere), rental (except for coastal area), relative humidity  $> 95\%$

### COMPLIANT WITH INTERNATIONAL STANDARDS

The LSA 44.3 alternator conforms to the main international standards and regulations:  
- IEC 60034, NEMA MG 1.32-33, ISO 8528-3, CSA / UL 1146 (UL 1004 on request), marine regulations, etc.

It can be integrated into a CE marked generator.

The LSA 44.3 is designed, manufactured and marketed in an ISO 9001 environment and ISO 14001.

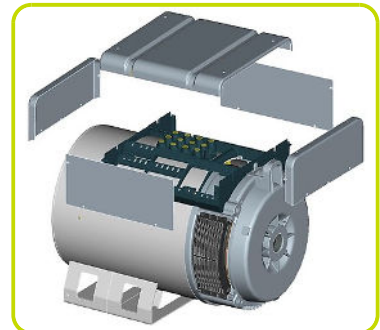

**CANOPY**

Canopy painted in RAL9016 made up of modular panels with 1000h+ tested salt spray resistant zinc metal sheet, with access doors on each side with high quality gaskets and lockable handles for easy maintenance and service.



**SUPER SILENT**

Soundproofing by means washable and fireproof soundproofing material, to get noise attenuation.

Exhaust silencer integrated in the genset shape with flat rain flap.



**BASE FRAME**

Heavy duty base guarantees the highest standards of durability and resistance, painted using a high quality powder coating process (1000+h tested salt spray resistance).

Fully bundled, able to retain 110% of all the sets fluids, the base frame is provided with integrated fork pockets and pull bar for easy maneuverability and site positioning.



**FUEL TANK**

Integrated metal fuel tank complete with double fuel refiling point (one each side)



**LEAK PROOF TRAY WITH DETECTOR SENSOR**

Fluid leak check in the leak proof tray .

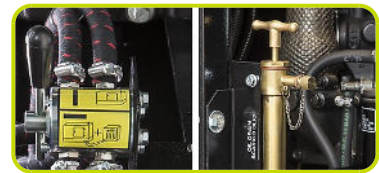

**FUEL VALVE (6 WAY)**

System designed for use the fuel from external tank and increase the autonomy of the generator



**LUBE OIL DRAIN PUMP**

Makes it easier to the engine oil change



**SINGLE LIFTING POINT**

Access easy by rung and handle incorporated (available on both sides)



**PLASTIC BUMPER**

Protections for the transport and stocking



**MANUAL BATTERY SWITCH**

**EARTH ROD**

Earth stock with cable fixed inside the genset

**DOCS HOLDER**

Box intenal for documents, manuals and electrical drawings



### Dimensional data

Length	(L) mm	3460
Width	(W) mm	1200
Height	(H) mm	2050
Dry weight	Kg	2660
Fuel tank material		Metal
Fuel tank capacity	l	940



### Autonomy

[50Hz] Fuel consumption @ 100% PRP	l/h	34.97
[50Hz] Fuel consumption @ 75% PRP	l/h	28.17
[50hz] Running time @ 75% PRP	h	33.37
[50Hz] Running time @ 100% PRP	h	26.88
[60Hz] Fuel consumption @ 75% PRP	l/h	32.77
[60Hz] Fuel consumption @ 100% PRP	l/h	39.75
[60hz] Running time @ 75% PRP	h	28.68
[60Hz] Running time @ 100% PRP	h	23.65



### Noise level 50Hz

Guaranteed noise level (LWA)	dB(A)	95
Noise pressure level @ 1 m	dB(A)	77
Noise pressure level @ 7 m	dB(A)	66



### Installation data

[50Hz] Cooling air	m³/min	277.62
[50Hz] Exhaust gas flow @ PRP	m³/min	24
[50Hz] Exhaust gas temperature @ LTP	°C	513
[60Hz] Cooling air	m³/min	343.92
[60Hz] Exhaust gas flow @ PRP	m³/min	28.77
[60Hz] Exhaust gas temperature @ LTP	°C	450



### Control panel availability

MANUAL CONTROL PANEL	MCP
AUTOMATIC CONTROL PANEL	ACP
MODULAR PARALLEL PANEL	MPP

## MCP - Manual Control Panel

Mounted on the genset, complete with digital control unit (InteliNanoNT Plus) for monitoring, control and protection of the generating set, protected through doors with lockable handle.

### CONTROL SECTION

- ON/OFF selector switch
- Emergency push button
- Differential protection with internal switch
- 5A Battery charger.
- Potentiometer for voltage adjustment (internal)
- Alternator AVR (single plug wiring)

### Control unit InteliNanoNT Plus

- Biggest LCD screen
- Generating set voltage (3 phases).
- Generating set frequency.
- Generating set current (1 phases).
- Battery voltage, Service time and Running hours indication
- Remote start/stop from external signal

### Protection:

- Low fuel level
- Battery charger failure
- low oil pressure
- high engine temperature

### Extra Instrumentation (analogue)

- Voltmeter with selector switch (3 phases)
- Ammeters (n.3)
- Fuel level meter
- Mechanical hour counter

### POWER SECTION

- It integrates 4 poles modular circuit breaker suitably rated with thermal and magnetic overloads.
- Large and robust busbar with cables passage opening from the bottom for easy power cable connection.
- Provided with safety switch to trip circuit breaker if operator open the power section door to operate on the bus bar.

### SOCKET SECTION

Two wires facility for remote start/stop	√
• Plug for auxiliary power supply	√
SUPPLEMENT - Only available when order	:
Socket Kit	Type SPKB1
3P+N+T CEE 400V 125A	n 1
3P+N+T 400V 63A	n 1
3P+N+T CEE 400V 32A	n 1
3P+N+T CEE 400V 16A	n 1
2P+T CEE 230V 16A	n 1
230V 16A SCHUKO	n 1
Each socket with its own circuit breaker	•
Common differential protection for three phase sockets	•
Each single phase provided with earth fault protection	•
Other Kit Socket combinations available	√

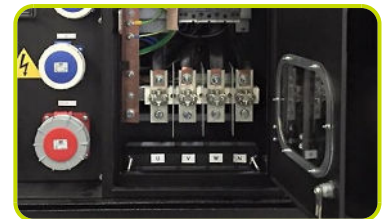

## ACP - Automatic Control Panel

Mounted on the genset, complete with digital control unit (AC-03) for monitoring, control and protection of the generating set, protected through doors with lockable handle.

### CONTROL SECTION

- ON/OFF selector switch
- Differential protection with internal switch
- 5A Battery charger.
- Potentiometer for voltage adjustment (internal)
- Alternator AVR (single plug wiring)

### Control unit (AC-03)

- Generating set voltage (3 phases).
- Mains voltage.
- Generating set frequency.
- Generating set current (3 phases).
- Battery voltage.
- Power (kVA - kW - kVAR - Cos  $\phi$ ).
- Hours-counter.
- Engine speed r.p.m.
- Fuel level (%).
- Engine temperature

### Command and others:

- Four operation modes: OFF - Manual starting - Automatic starting - Test.
- Pushbutton for forcing Mains contactor or Genset contactor.
- Push-buttons: start/stop, fault reset, up/down/page/enter selection.
- Remote starting availability.
- Acoustic alarm.
- Automatic battery charger.
- RS232 Communication port.
- Settable PASSWORD for protection level

### Protections:

- Engine protections: low fuel level, low oil pressure, high engine temperature,
- Genset protection: under/over voltage, overload, under/over battery voltage, battery charger failure.

### Extra Instrumentation (analogue)

- Fuel level meter
- Mechanical hour counter

### POWER SECTION

- It integrates 4 poles modular circuit breaker suitably rated with thermal and magnetic overloads.
- Large and robust busbar with cables passage opening from the bottom for easy power cable connection.
- Provided with safety switch to trip circuit breaker if operator open the power section door to operate on the bus bar.

### SOCKET SECTION

Two wires facility for remote start/stop		✓
• Plug for auxiliary power supply		✓
• Multipin connector for LTS		✓
SUPPLEMENT - Only available when order		:
Socket Kit	Type	SPKB1
3P+N+T CEE 400V 125A	n	1
3P+N+T 400V 63A	n	1
3P+N+T CEE 400V 32A	n	1
3P+N+T CEE 400V 16A	n	1
2P+T CEE 230V 16A	n	1
230V 16A SCHUKO	n	1
Each socket with its own circuit breaker		•
Common differential protection for three phase sockets		•
Each single phase provided with earth fault protection		•
Other Kit Socket combinations available		✓





## MPP - Modular Parallel Panel

Mounted on the genset, complete with digital control unit IntelliVision5 for monitoring, control, protection and load sharing for both single and multiple gen-sets operating in standby or parallel modes (up to 32 gen-sets in island).

### CONTROL SECTION

- ON/OFF selector switch
- Emergency push button
- Differential protection with internal switch
- 5A Battery charger.
- Potentiometer for voltage adjustment (internal)
- Alternator AVR (single plug wiring)

### CONTROL UNIT IntelliVision5 (5,7" Colour TFT display 320×240 pixels)

#### Majors Measures Available:

- Generating set: Voltage, Current, Frequency, Hours-counter
- Generating set Power: kVA, kW, kVAr, Cos φ, kWh, kVAh.
- Mains: Voltage, Current, Frequency, kW, kVAr, Cos φ.
- Engine: Speed (r.p.m.), Temperature, Oil Pressure
- Fuel level, Battery voltage

#### Comand and Others:

- Operation modes: OFF, AMF function, Single Parallel to mains Island application, Single Parallel to Mains AMF application, Multiple parallel genset Island application.
- Pushbuttons: start/stop, fault reset, up/down/page/enter selection.
- Acoustic alarm.

#### Protection:

- Engine protections: low fuel level, low oil pressure, high engine temperature.
- Genset protections: under/over voltage, overload, under/over frequency, starting failure, under/over battery voltage
- Others: overcurrent, shortcircuit, reverse power, Earth fault

#### Extra Instrumentation (analogue)

- Fuel level meter
- Mechanical hour counter

### POWER SECTION

- It integrates 4 poles motorized moulded case circuit breaker suitably rated with thermal and magnetic overloads
- Large and robust busbar with cables passage opening from the bottom for easy power cable connection.
- Provided with safety switch to trip circuit breaker if operator open the power section door to operate on the bus bar.

### SOCKET SECTION

- Multi-pin connectors for paralle running ✓
- Two wires facility for remote start/stop ✓
- Plug for auxiliary power supply ✓

SUPPLEMENT - Only available when order :

Socket Kit	Type	SPKB1
3P+N+T CEE 400V 125A	n	1
3P+N+T 400V 63A	n	1
3P+N+T CEE 400V 32A	n	1
3P+N+T CEE 400V 16A	n	1
2P+T CEE 230V 16A	n	1
230V 16A SCHUKO	n	1
Each socket with its own circuit breaker		•
Common differential protection for three phase sockets		•
Each single phase provided with earth fault protection		•
Other Kit Socket combinations available		✓

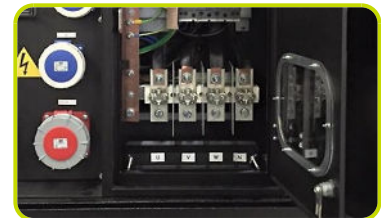

## Supplements:

To be ordered with the equipment :

### GENSET CONTROL EQUIPMENT

Dual Frequency Switch (50/60Hz)	Y400/230V 50Hz Y480/277V 60Hz	DFS
Voltage Selector Switch 2 positions (only with ACP/MPP and DFS)	Y400/230V 50Hz Y480/277V 60Hz YY208/120V 60Hz	VSS1
Voltage Selector Switch 3 positions (only with ACP/MPP and DFS)	Y400/230V 50Hz Δ230V 3P 50Hz Y480/277V 60Hz YY208/120V 60Hz	VSS2
Voltage Selector Switch 2 positions (only with ACP/MPP and DFS)	Y400/230V 50Hz Δ230V 3P 50Hz Y480/277V 60Hz	VSS4

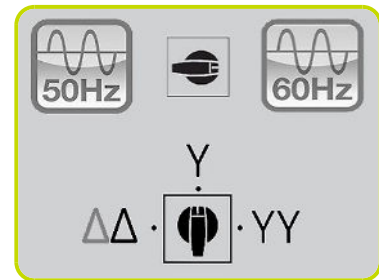

### ELECTRICAL OPTION

Remote control trough IL-NT-GPRS + ANTENNA Available for	(ACP)	RCG 16
Free Voltage Contacts with module IL-NT-EFCPM2 + IR-B8 relay board	(ACP)	TLP 6
Remote control trough with InternetBridge-NT	(only with MPP)	RCG 13
Free Voltage Contacts with module IGS-PTM +IR-B8 relay board	(only with MPP)	TLP 4
Differential Protection type B		ADI-B
Insulation Monitoring Device (Replace standard differential protection)		IMD
Socket Section Customized		SPKS
Control section internal lighting (automatic with door switch)		CLS
Internal Canopy Lighting system with manual switch		ICL
Engine analogue gauges (water temp / oil pressure)		EAG



### MECHANICAL OPTION

Pre-heating system		PHS
Quick Fit Fuel connectors		QFC
Quick Fit Connectors inside the canopy		QFC1
Water Separator Filter		WSP
Heavy-Duty Air Filter		HDF
Hot Parts Protections		HPP
Exhaust Spark Arrestor ATEX certified		ESA
Air Shut-Off Valve		ASV
Galvanized Sliding Skid		GGs
Baseframe Bumpers		BFB



## Accessories

Items available as accessory equipment	:
RTR-B Road Trailer with Drawbar Height-Adjustable	•
RTR - Road Trailer	•
STR - Site trailer	•



### LTS - Load Transfer Switch [Accessories for ACP Automatic Control Panel]

The Load Transfer Switch (LTS) panel operates the power supply changeover between the generator and the Mains in backup applications, guarantying the feeding to the load within a short period of time.

It consists of a standalone cabinet which can be installed separate from the generating set. The logic control of the power supply changeover is operated by means of the Automatic Control Panel (ACP) mounted on the generating set, so therefore none logic device is required on the LTS panel.

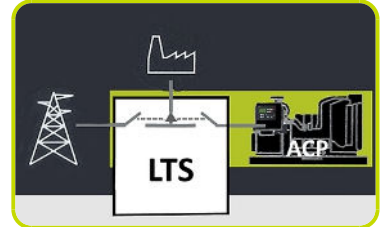

#### LTS Type ATyS\_D:

- Box type: steel enclosures
- Installation mode: Wall mounted <400A; Floor Standing =>630A
- Door: Hinged door closed with double barb locking.
- Ingress Protection: IP43
- Gland Plates: Removable on the top & bottom side
- Connections: Bottom/Bottom
- Motor unit
- Gland Plates: Removable on the top & bottom side
- Connections: Bottom/Bottom
- Motor unit
- Switch position indicator
- Auto/Manual cover selector
- Housing for manual handle
- Padlocking mechanism
- Two side by side mounted load break switches
- Poles 4
- Double coils self-powered
- Voltage (coils): 208/277VAC (Tolerance+/-20% 166/333VAC)
- Frequency 50 & 60HZ
- Interface ATyS D10, fixed on the door for the status indication: Two lights to indicate the voltage presence of the grid and the diesel generator; Two lights for the switch position; Functionality mode (auto/manual) and cover protection IP65.
- Compliant with IEC 60947-3, EN 61439-6-1 and GB 14048-11



#### LTS SUPPLEMENTS AVAILABLE ON REQUEST:

- **ESB** - Emergency Stop Button (installed on the panel front)
- **APP** - Additional IPXXB Protection (internal plexiglass)

The information is aligned with the Data file at the time of download. Printed on 16/09/2019 (ID 3633)

©2019 | PR INDUSTRIAL s.r.l. | All rights reserved | Image shown may not reflect actual package. Specifications subject to change without notice

